

# DIG

dual digital delay

## USER MANUAL

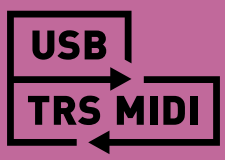

## Contents

<b>Knobs and Switches</b> .....	<b>3</b>
Front Panel Controls .....	3
<b>Rear Panel I/O and Control</b> .....	<b>5</b>
<b>Live Edit Functions</b> .....	<b>7</b>
Dry Level .....	7
Configuration Mode .....	9
Sync/Free Mode .....	12
Delay 1 Subdivision .....	13
Delay 2 Repeats .....	14
MIDI Clock Sync .....	15
Respond/Ignore MIDI Expression .....	16
<b>Power Up Modes</b> .....	<b>17</b>
Input Level .....	17
Bypass Mode .....	18
Spillover Mode .....	19
Configuring the EXP/MIDI Jack.....	20
<b>External Control</b> .....	<b>22</b>
Expression Pedal Setup .....	22
Favorite Switch Setup and Compare Mode .....	23
Tap Mode .....	25
Configuring MultiSwitch Plus .....	26
Using MultiSwitch Plus .....	27
Saving DIG Presets with MultiSwitch Plus: .....	27
<b>MIDI Functionality</b> .....	<b>28</b>
Configuring DIG to Use MIDI .....	28
Saving Presets in MIDI Mode .....	33
<b>MIDI Specifications</b> .....	<b>34</b>
MIDI Program Changes.....	34
MIDI CCs .....	35
<b>Factory Reset</b> .....	<b>36</b>
<b>Features</b> .....	<b>38</b>
<b>Specifications</b> .....	<b>39</b>
Power Adapter Requirements.....	39
<b>Appendix 1: Sample Settings</b> .....	<b>40</b>
<b>Appendix 2: Power Up Modes Quick Reference</b> .....	<b>42</b>
General Options .....	43
MIDI & Jack Options .....	44
<b>Appendix 3: Live Edit Controls Quick Reference</b> .....	<b>45</b>
<b>Strymon Non-Transferable Limited Warranty</b> .....	<b>47</b>

## Knobs and Switches

### Front Panel Controls

#### MOD

Sets the amount of modulation added to the delay lines:

- off:** no modulation
- light:** subtle modulation
- deep:** thick, rich modulation

#### TIME

Controls the delay time for Delay 1. Acts as a master time control for both delays. See [page 12](#) for details.

#### TIME 2

Sets the rhythmic subdivision relationship between Delay 1 and Delay 2. Select from triplet, eighth, golden ratio, dotted eighth, or dotted quarter.

#### TONE

Sets the feedback filter response. Turn counter-clockwise for high cut and clockwise for low cut. 12 o'clock provides a flat response.

#### TAP

Tapping the footswitch sets the master delay time. The **TAP** LED flashes **RED** to indicate the tempo.

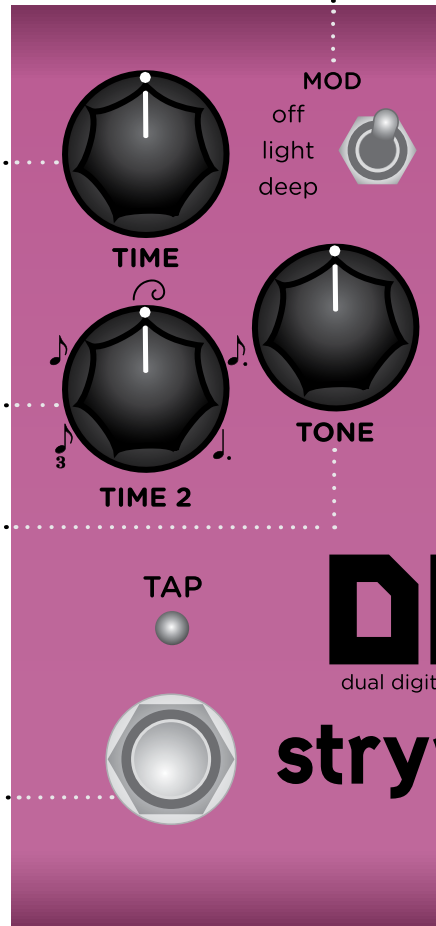

**NOTE:** Hold the **TAP** footswitch to engage circular repeats. Release the footswitch to return to normal operation.

## Knobs and Switches

### Front Panel Controls

#### TYPE

Changes the digital delay character:

**24/96:** modern, clean delay with subtle dynamics. The 24-bit resolution and 96kHz sampling rate ensure uncolored repeats

**adm:** early '80s adaptive delta modulation process provides a percussive wide-band delay that adds more character when input dynamics increase

**12 bit:** mid 80's 12-bit conversion method yields slightly darker and warmer delays

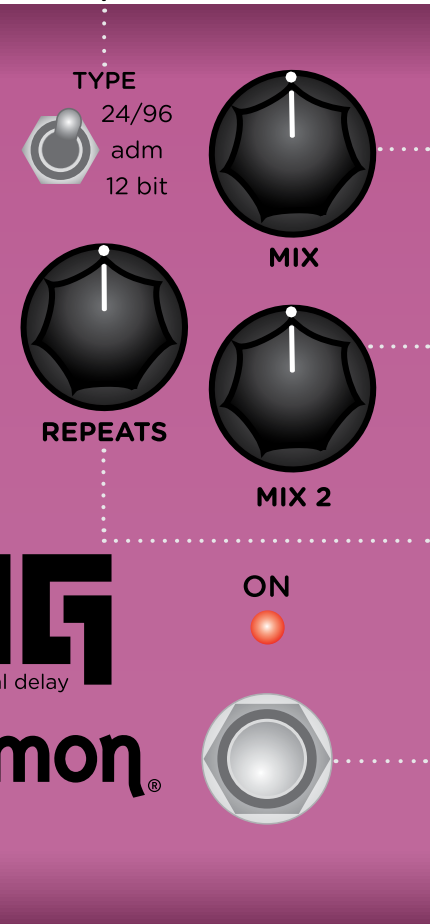

#### MIX

Controls the wet/dry mix for Delay 1. 50/50 mix is at the 3 o'clock position.

#### MIX 2

Controls the wet/dry mix for Delay 2. 50/50 mix is at the 3 o'clock position.

#### REPEATS

Adjusts the number of repeats for both delays. See [page 14](#) for details.

#### EFFECT ON

Engages and bypasses the effect. **RED** LED on indicates that the effect is engaged. Bypass mode is true bypass by default. See [page 18](#) for details.

## Rear Panel I/O and Control

### AUDIO INPUT SELECTOR

**MONO:** Use with a mono input signal, such as a guitar. Output is stereo. Use **OUT L** for mono connection.

**STEREO:** Use with a stereo input signal. Output is stereo.

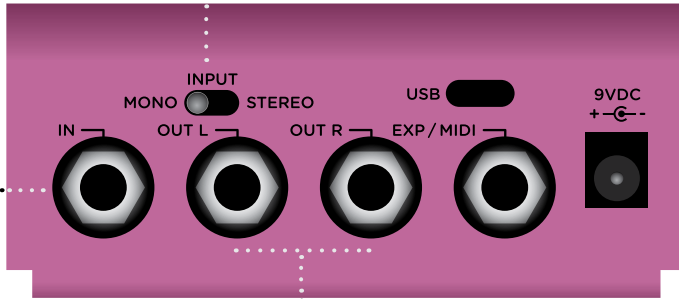

**IN**.....

High impedance, ultra low-noise, discrete Class A JFET preamp input. Use a TRS stereo adapter/cable for stereo input.

.....**OUTPUTS**

Low impedance stereo outputs. Use **OUT L** for mono output.

## Rear Panel I/O and Control (cont.)

### USB

Computer connection for MIDI control as well as for performing firmware updates.

### 9VDC

Use the included power supply or an adapter with the following rating:

- 9VDC, center negative
- 300mA minimum

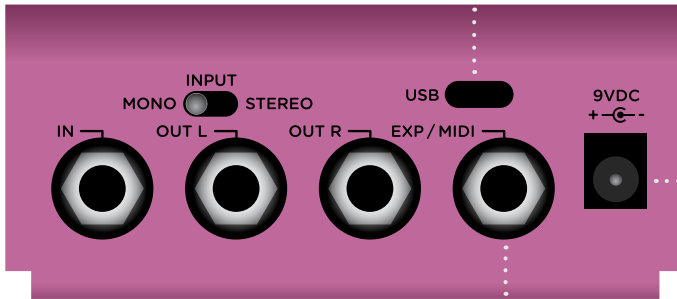

### EXP / MIDI

Multifunction communication jack for external control of DIG's features and functions. Can be set to operate in one of the following modes. (See [“Configuring the EXP/MIDI Jack” on page 20](#) for details.)

**Expression Pedal mode** (see [page 22](#)).

**Favorite mode** (see [page 23](#)).

**Tap mode** (see [page 25](#)).

**MIDI mode** (see [“Configuring MultiSwitch Plus” on page 26](#) or [“Saving Presets in MIDI Mode” on page 33](#)).

## Live Edit Functions

Use the following steps to enter Live Edit mode and access the secondary functions of the controls. Any of the following secondary functions can be edited while in Live Edit mode.

### Dry Level

By default, the Dry Level is set to “Track Mix,” where the Dry Level is controlled via the **MIX** and **MIX 2** knobs. Optionally, you can adjust the dry signal level manually.

- 1 Press and hold the **ON** footswitch to enter Live Edit mode. Once both LEDs flash, release the footswitch.



- 2 Turn the **MIX (DRY LEVEL)** knob to set the level of the dry signal. Both the **TAP** and **ON** LEDs light to indicate your selection:

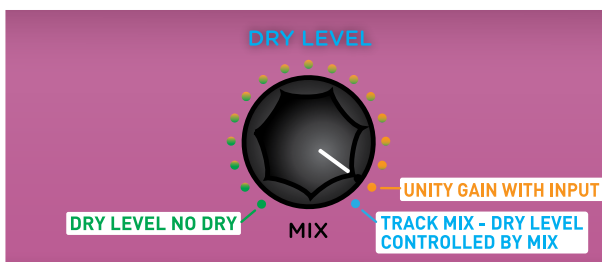

- Manually adjust the Dry Level smoothly from no dry signal at minimum (**GREEN**, useful when DIG is connected in a parallel effects loop) to maximum dry signal, where the dry matches the dry input signal level (**AMBER**).

- Set to Track Mix (**BLUE**, default) for the amount of dry/wet balance to be adjusted using the **MIX** and **MIX 2** knobs.

**3** Press the **ON** footswitch to exit and store your Dry Level setting.

**NOTE:** The Dry Level setting is saved per Favorite setting or per MIDI preset.



## Live Edit Functions

### Configuration Mode

Sets the dual delay configuration for Series, Ping Pong, or Parallel.

- 1 Press and hold the **ON** footswitch to enter Live Edit mode. Once both LEDs flash, release the footswitch.



- 2 Turn the **MIX 2 (CONFIG)** knob to choose the desired dual delay configuration. The **ON** LED color indicates your selection.

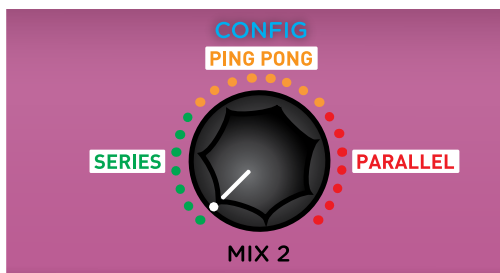

- Turn to the left for Series configuration (**GREEN**, default).
- Turn to the center for Ping Pong configuration (**AMBER**).
- Turn to the right for Parallel configuration (**RED**).

**NOTE:** See [“Dual Delay Configuration Modes” on page 10](#) for details.

- 3 Press the **ON** footswitch to exit and store your configuration setting.

**NOTE:** The Configuration Mode setting is saved per Favorite setting or per MIDI preset.

## Dual Delay Configuration Modes

### Series

In Series configuration, Delay 2 (the rhythmic sub-delay) feeds Delay 1 in the following manner:

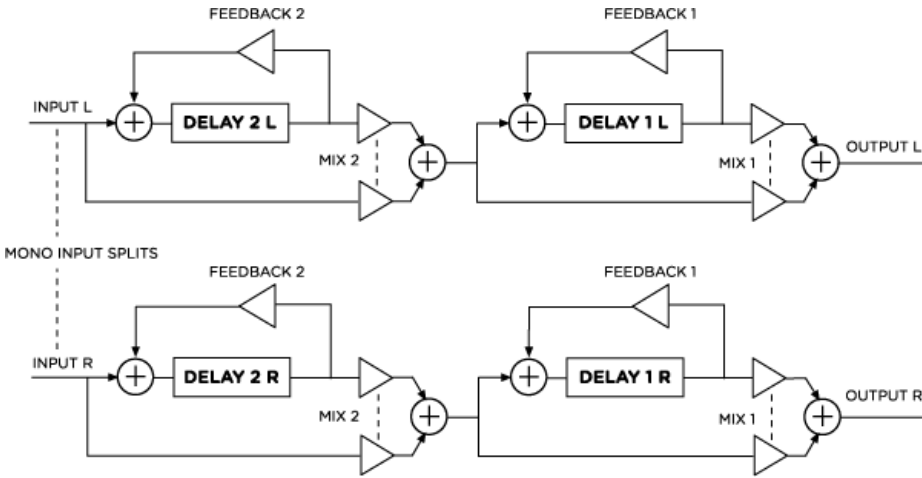

Series configuration diagram

This is equivalent to putting two single delay pedals in succession on your pedalboard. A mono input feeds both left and right channels.

### Ping Pong

In Ping Pong mode, the delays are configured in a series “ping-pong” structure.

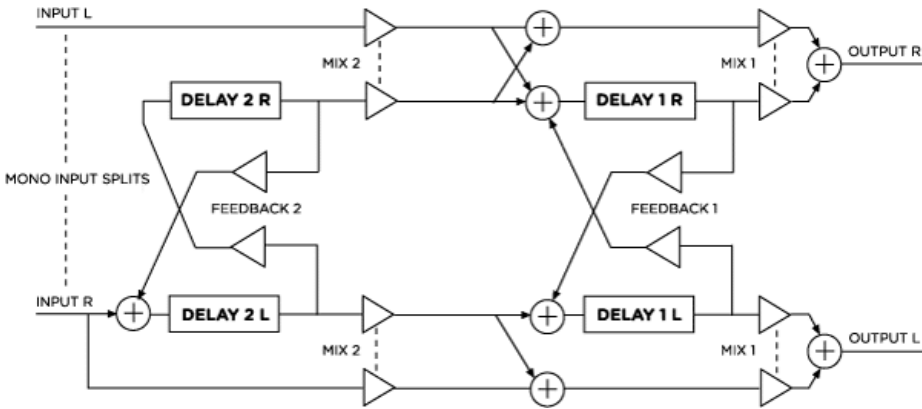

Ping Pong configuration diagram

In stereo, each delay acts as a ping-pong delay, and they interact when both MIX knobs are turned up. When using a mono output signal, this configuration is the same as the Series configuration.

## Dual Delay Configuration Modes (cont.)

### Parallel

In Parallel configuration, the delays do not interact with each other, but produce their outputs “side-by-side.”

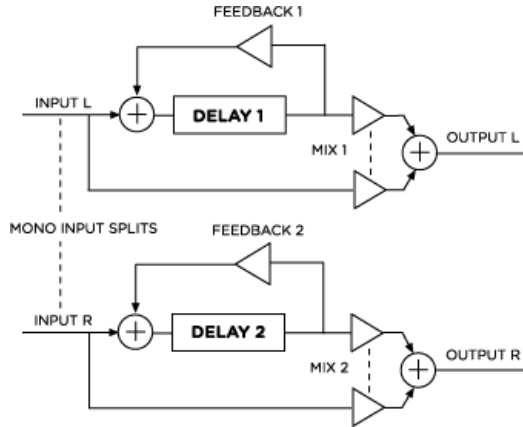

Parallel configuration diagram

In stereo, Delay 1 outputs to the left channel and Delay 2 outputs to the right channel. When the right output is not used, the wet signal sums to mono so that both parallel delays are heard from the left output.

## Live Edit Functions

### Sync/Free Mode

Enables and disables time sync and subdivisions between Delay 1 and Delay 2.

- 1 Press and hold the **ON** footswitch to enter Live Edit mode. Once both LEDs flash, release the footswitch.



- 2 Turn the **TIME 2 (SYNC/FREE MODE)** knob to select the mode. Both LEDs will light to indicate your selection:

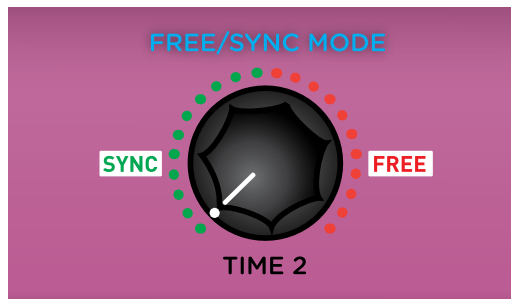

- Turn counter-clockwise to engage Sync Mode (**GREEN**, default) which enables time sync and subdivisions between Delay 1 and Delay 2.
- Turn clockwise for Free mode (**RED**), which provides the **TIME 2** knob with a full delay range from 20ms to 1.6s.

- 3 Press the **ON** footswitch to exit and store your setting.

**NOTE:** The Sync/Free mode setting is saved per Favorite setting or per MIDI preset.

## Live Edit Functions

### Delay 1 Subdivision

Sets a Tap Tempo subdivision for Delay 1.

- 1 Press and hold the **ON** footswitch to enter Live Edit mode. Once both LEDs flash, release the footswitch.



- 2 Turn the **TIME (DELAY 1 SUBDIVISION)** knob to set the desired subdivision value. The **TAP** LED lights to indicate your selection:

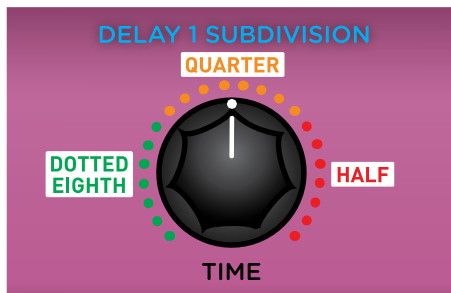

- Turn left for Dotted Eighth note (**GREEN**)
  - Turn to center for Quarter note (**AMBER**, default)
  - Turn right for Half note (**RED**)
- 3 Press the **ON** footswitch to exit and store your Delay 1 Subdivision setting.

**NOTE:** The Delay 1 Subdivision setting is saved per Favorite setting or per MIDI preset.

## Live Edit Functions

### Delay 2 Repeats

Sets the number of repeats for Delay 2 independently, or to track the REPEATS knob setting for Delay 1.

- 1 Press and hold the **ON** footswitch to enter Live Edit mode. Once both LEDs flash, release the footswitch.



- 2 Turn the **REPEATS (DELAY 2 REPEATS)** knob to set the desired repeats for Delay 2. Both the **TAP** and **ON** LEDs indicate your selection:

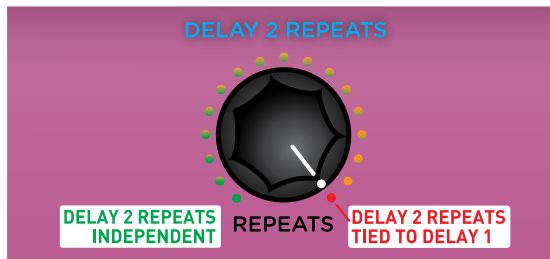

- Turn **REPEATS** from minimum to independently set Delay 2's number of repeats (from **GREEN** through **AMBER**).
- Set knob to maximum to tie the repeats of Delay 1 and Delay 2 together (**RED**, default).

- 3 Press the **ON** footswitch to exit and store your Delay 2 Repeats setting.

**NOTE:** The Delay 2 Repeats setting is saved per Favorite setting or per MIDI preset.

## Live Edit Functions

### MIDI Clock Sync

Selects whether the delay time for Delay 1 will sync to incoming MIDI Clock messages.

- 1 Press and hold the **ON** footswitch. Once both LEDs flash, release the footswitch.



- 2 Set the position of the **TYPE (MIDI CLOCK SYNC)** switch to select whether DIG will sync to incoming MIDI Clock messages. Both LEDs will momentarily change color to indicate the current status as you set the switch.
  - Set the switch down to **12 bit** for **Off** (default): both LEDs light **RED** - DIG will not respond to MIDI Clock.
  - Set the switch up to **24/96** for **On**: both LEDs light **BLUE** - DIG will respond to MIDI Clock.

**NOTE:** When synced to MIDI Clock, the LEDs will light **PINK**, and the **TIME** knob will act as a multiplier or divider of the incoming clock tempo. The synced **TIME** mult/div settings are: x4 (min), x3, x2, x1 (at 12 o'clock), 1/2, 1/3, and 1/4 (max).

- 3 Press the **ON** footswitch to exit and store your MIDI Clock setting.

**NOTE:** The MIDI Clock setting is saved per Favorite setting or per MIDI preset.

## Live Edit Functions

### Respond/Ignore MIDI Expression

When set to MIDI mode, this setting determines whether DIG will respond to MIDI Expression CC# 100, values 0 (heel) to 127 (toe), to control the knob settings in the same manner as a TRS Expression pedal.

- 1 Press and hold the **ON** footswitch. Once both LEDs flash, release the footswitch.



- 2 Set the position of the **MOD (MIDI EXP)** switch to select whether DIG will respond to MIDI Expression CC# 100. Both LEDs will momentarily change color to indicate the current status as you set the switch.
  - Set the switch down to **deep** for **Disabled**: both LEDs light **RED** - DIG will not respond to MIDI Expression.
  - Set the switch up to **off** for **Enabled**: both LEDs light **BLUE** (default) - DIG will respond to MIDI Expression.
- 3 Press the **ON** footswitch to exit and store your MIDI Expression setting.

**NOTE:** The MIDI Expression setting is saved per Favorite setting or MIDI preset.



## Power Up Modes

### Input Level

Selects the input level that is routed to the effect processing.

- 1 Press and hold the **ON** footswitch while powering up DIG. Once both LEDs flash, release the footswitch.



- 2 Turn the **TIME (INPUT LEVEL)** knob to select the Input Level mode. Both LEDs will change color to indicate the current status as you turn the knob.

- **Instrument: GREEN** (default) - Input headroom is set for an instrument level source, such as a guitar or a bass.
- **Line: RED** - Input level is set for a line level source, such as a keyboard or synthesizer. 10dB of headroom is added.

- 3 Press either footswitch to store the Input Level setting and begin using DIG.

**NOTE:** The Input Level setting persists across power cycles and is not saved per preset.

## Power Up Modes

### Bypass Mode

Setting DIG to Buffered Bypass mode preserves the high frequency response of your guitar signal through your pedal chain and long cable runs.

- 1 Press and hold the **ON** footswitch while powering up DIG. Once both LEDs flash, release the footswitch.



- 2 Turn the **MIX (BYPASS MODE)** knob to choose between True Bypass or Buffered Bypass modes. The **ON** LED will change color to indicate the current status as you turn the knob.
  - True Bypass: **GREEN** (default).
  - Buffered Bypass: **RED**
- 3 Press either footswitch to store the Bypass Mode and begin using DIG.

**NOTE:** The Bypass Mode setting persists across power cycles and is not saved per preset.

## Power Up Modes

### Spillover Mode

Setting DIG to Spillover Mode allows the wet delay signal of a currently selected preset to “spill” into bypass or the next selected preset.

**NOTE:** Because of the delay buffer architecture, the current preset must be active for at least 5 seconds before Spillover between presets will be operational. Spillover is available immediately when bypassing the effect.

- 1 Press and hold the **ON** footswitch while powering up DIG. Once both LEDs flash, release the footswitch.



- 2 Turn the **TONE (SPILLOVER MODE)** knob to turn Spillover Mode on or off. Both LEDs will change color to indicate the current status as you turn the knob.
  - Spillover Mode Off: **AMBER** (default)
  - Spillover Mode On: **PURPLE**
- 3 Press either footswitch to store the Spillover Mode setting and begin using DIG.

**NOTE:** The Spillover Mode setting persists across power cycles and is not saved per preset.

## Power Up Modes

### Configuring the EXP/MIDI Jack

- 1 Press and hold the **TAP** footswitch while powering up DIG. Once both LEDs flash, release the footswitch.



- 2 Turn the **MIX (EXP/MIDI JACK)** knob to select the function of the rear panel's EXP/MIDI jack. The **ON** LED will change color to indicate the current status as you turn the knob.

- **Expression Pedal mode: GREEN** (default) - Allows continuous control over any of the knobs in any direction with a standard TRS expression pedal. (See [page 22](#) for details.)
- **Favorite mode: AMBER** - Allows you to recall a Favorite setting using a Strymon MiniSwitch. (See [page 23](#) for details.)
- **Tap mode: RED** - Allows you to set the master delay time via tap tempo using a Strymon MiniSwitch. (See [page 25](#) for details.)
- **MIDI mode: BLUE** - Allows for the selection of three presets using a Strymon MultiSwitch Plus. Full MIDI functionality is also available by sending MIDI Program Change messages via 1/4" TRS MIDI connection using a Strymon Conduit or MIDI EXP cable. Up to 300 presets are available via MIDI. (See ["Configuring MultiSwitch Plus"](#) on [page 26](#) or ["Saving Presets in MIDI Mode"](#) on [page 33](#).)

## Configuring the EXP/MIDI Jack (cont.)



- 3 Press either footswitch to store the EXP/MIDI jack mode and begin using DIG.

**NOTE:** The EXP/MIDI jack mode setting persists across power cycles and is not saved per preset.

## External Control

### Expression Pedal Setup

Use a TRS expression pedal to control the knobs of DIG .

- 1 Configure the **EXP/MIDI** jack for Expression mode. (See [page 20](#) for configuration instructions.)
- 2 Connect an expression pedal to the **EXP/MIDI** jack of DIG using a TRS cable.

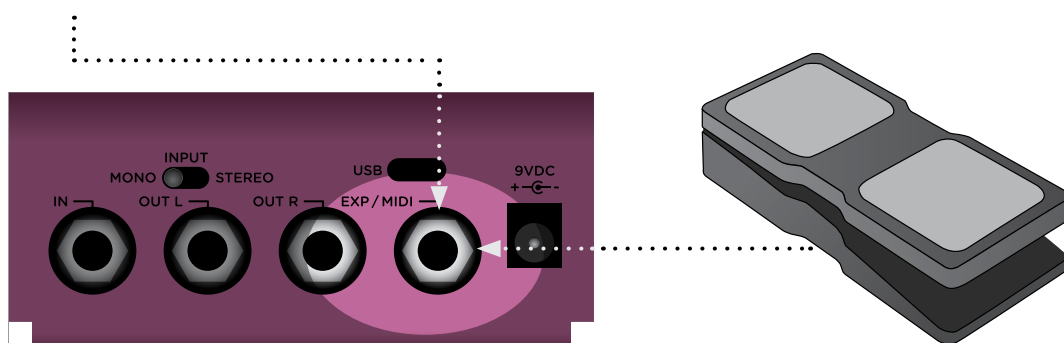

- 3 Press and hold both footswitches until both LEDs blink **GREEN**.
- 4 Rock the expression pedal to the **HEEL** position. Only the **TAP** LED will blink **GREEN**.
- 5 Set the knob(s) you would like to control to the desired settings for the **HEEL** position of the expression pedal. Only the **TAP** LED will turn **RED**.
- 6 Rock the expression pedal to the **TOE** position. Only the **ON** LED will blink **GREEN**.
- 7 Set the knob(s) you would like to control to the desired settings for the **TOE** position of the expression pedal. Only the **ON** LED will turn **RED**.
- 8 Press either footswitch to exit and store your expression pedal setup.

**NOTE:** Your expression pedal assignment is saved per Favorite setting or MIDI preset.

**NOTE:** If DIG is set to respond to **MIDI EXPRESSION** and the **EXP/MIDI** jack is set to MIDI mode, you can send MIDI CC# 100 with values 0 (heel) to 127 (toe) to perform the expression pedal setup.

## External Control

### Favorite Switch Setup and Compare Mode

Connect a MiniSwitch or other external latching footswitch with a TRS cable to store and recall your favorite setting.

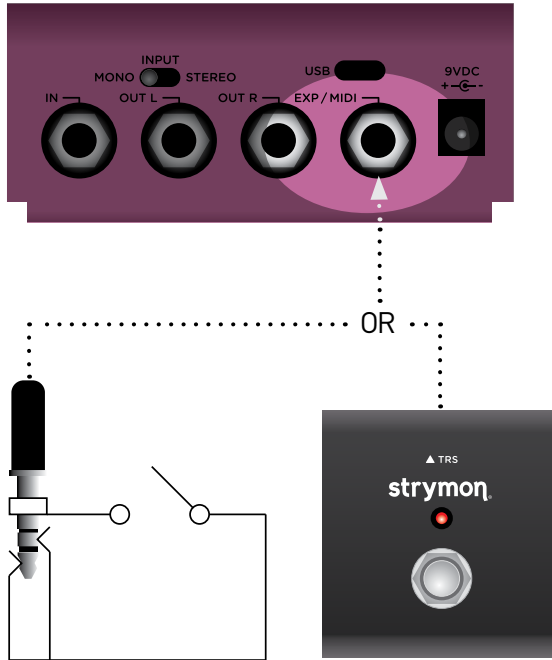

- 1 Configure the **EXP/MIDI** jack for Favorite mode. (See [page 20](#) for more info.)
- 2 Connect an external switch with a TRS cable to the **EXP/MIDI** jack.
- 3 Dial in your desired sound.
- 4 To save your sound as the new Favorite setting, press and hold both footswitches until they blink **GREEN**. Then, press and hold the **TAP** footswitch until the **TAP** LED momentarily flashes **BLUE** to save the Favorite setting.

Step on the external footswitch to toggle between your Favorite setting and the current setting on DIG.

## Favorite Switch Setup and Compare Mode (cont.)

### Compare Mode

With the Favorite or MIDI preset recalled, as a knob or switch is adjusted, both LEDs flash **GREEN** when the current knob or toggle switch position matches the setting of the preset.

**NOTE:** Along with the knobs and toggle switches on the face of the pedal, all Live Edit settings and DIG's bypass state are stored with the Favorite and MIDI presets. Power Up modes are not stored with the presets.

**NOTE:** Saving presets works differently when using MIDI. (See [page 28](#) for details.)

**NOTE:** The Favorite setting is stored at MIDI program change location 0.



## External Control

### Tap Mode

Connect a MiniSwitch or other external momentary footswitch with a TRS cable to tap in a delay time for Delay 1.

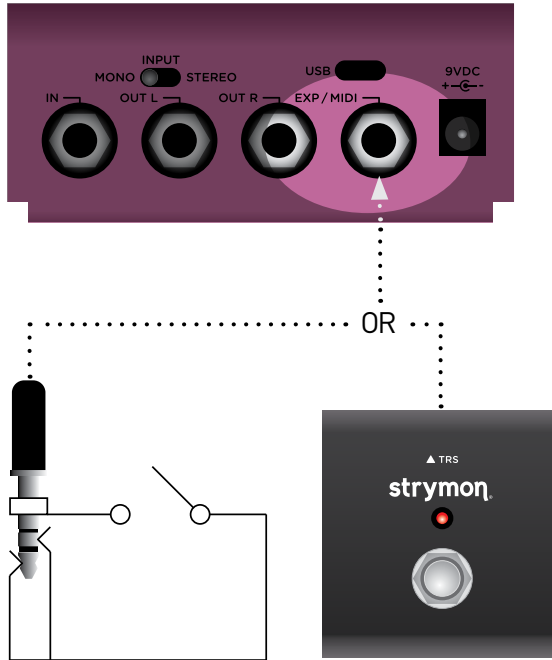

- 1 Configure the **EXP/MIDI** jack for Tap Mode. (See [page 20](#) for more info.)
- 2 Connect an external switch with a TRS cable to the **EXP/MIDI** jack.
- 3 Tap in a tempo in quarter notes to set the delay time for Delay 1.

**NOTE:** When in Tap Mode, press and hold the external switch to engage circular repeats. Release the footswitch to return to normal operation.

## External Control

### Configuring MultiSwitch Plus

Configure DIG and MultiSwitch Plus for remote access to three additional presets.

- 1 Press and hold the **TAP** footswitch while connecting power to the pedal. Hold until both LEDs stop blinking.
- 2 Turn the **TIME** knob all the way counter-clockwise to set the MIDI channel to Channel 1. The **TAP** LED should be **GREEN**.
- 3 Turn the **TONE** knob to select any of the following **MIDI OUT** options (both LEDs will show the following indicated colors):
  - Send MIDI CC, PC, and Other Data: **WHITE**
  - Send MIDI CC and Other Data: **GREEN**
  - Send MIDI PC and Other Data: **PURPLE**
  - Send Other Data: **AMBER**
- 4 Turn the **MIX** knob all the way clockwise to set the **EXP/MIDI** jack to MIDI mode. The **ON** LED should be **BLUE**.
- 5 Press either footswitch to exit and store the MIDI channel, the **MIDI OUT** setting, and the **EXP/MIDI** jack mode.
- 6 Connect a TRS cable to DIG's **EXP/MIDI** jack.

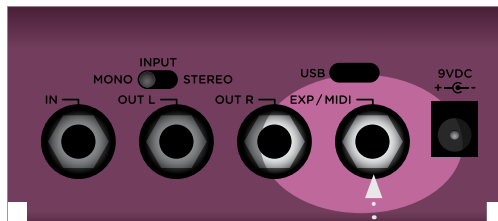

- 7 Press and hold the **A** footswitch on MultiSwitch Plus while connecting the other end of the TRS cable to any one of the three jacks to set it to Preset mode.



## External Control

### Using MultiSwitch Plus

Selecting and saving DIG presets using MultiSwitch Plus.



**NOTE:** Footswitches A, B, and C on MultiSwitch Plus correspond to MIDI Program Changes 1, 2, and 3.

- 1 Step on a switch that is not illuminated to recall the corresponding preset.
- 2 Step on an illuminated switch to bypass DIG.

### Saving DIG Presets with MultiSwitch Plus:

- 1 Dial in the sound that you would like to save as your preset on DIG.
- 2 Press and hold both footswitches on DIG until both the LEDs blink **GREEN**.
- 3 Press the A, B, or C footswitch on MultiSwitch Plus to save the current state of the pedal to the desired location.

## MIDI Functionality

### Configuring DIG to Use MIDI

Using MIDI unlocks a set of tools that can be used to load any of DIG's 300 preset locations using a suitable MIDI controller or interface connected to the DIG EXP/MIDI jack. This requires a Strymon MIDI EXP cable or a MIDI controller/interface, such as Strymon Conduit, with at least one quarter-inch output.

**NOTE:** When using a Strymon MIDI EXP Cable, the MIDI OUT mode must be set to Off. (See [page 32](#) for more info.)

Please see [strymon.net/support/dig-v2](http://strymon.net/support/dig-v2) for a list of compatible devices.

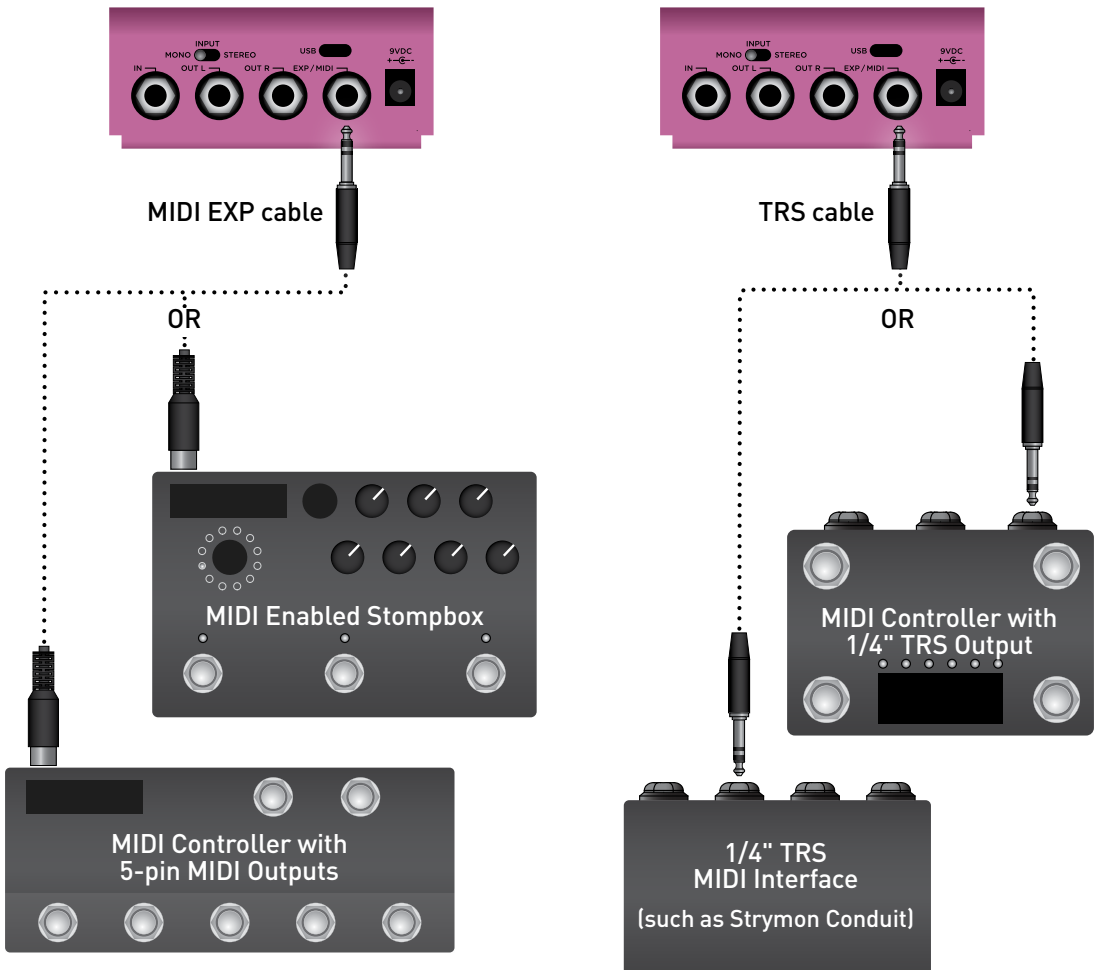

## Configuring DIG to Use MIDI (cont.)

### STEP 1 – SET EXP/MIDI JACK TO MIDI MODE

- 1 Press and hold the **TAP** footswitch while connecting power to the pedal. Once both LEDs flash, release the footswitch.



- 2 Turn the **MIX** knob clockwise until the **ON** LED is **BLUE** to select MIDI mode.

## Configuring DIG to Use MIDI (cont.)

### STEP 2 – SET MIDI CHANNEL



**3** Turn the **TIME** knob to set the MIDI communication channel. The **TAP** LED indicates status. Your **TIME** knob selections are as follows:

- Channel 1: **GREEN** (default)
- Channel 2: **AMBER**
- Channel 3: **RED**
- Channel 4-16: **BLUE** (set by next received MIDI Program Change message, requires 1/4" MIDI connection)

Once the **TAP** LED turns **BLUE**, it will blink until the pedal receives a MIDI Program Change message. Once a message is received, the pedal will be set to the MIDI channel that carried the message and exit the power-up mode to allow you to begin using DIG.

## STEP 2 – SET MIDI CHANNEL (CONT.)



- 4 Press **either** footswitch to exit and store your MIDI Channel setting and begin using DIG.

**NOTE:** A simple way to check that communication is working is to send CC #102 with a value of 127 when the **ON** footswitch is off. This will enable the **ON** footswitch if MIDI is properly connected and configured.

**NOTE:** If you are only sending data to DIG using the Strymon MIDI EXP Cable, the MIDI OUT mode must be set to **OFF**. (See [page 32](#) for details on configuring the MIDI OUT mode.)

**NOTE:** MIDI Channel assignment is not saved per Favorite setting or MIDI preset.

## Configuring DIG to Use MIDI (cont.)

### STEP 3 – SET MIDI OUT MODE

- 1 Press and hold the **TAP** footswitch while connecting power to the pedal. Once both LEDs flash, release the footswitch.



- 2 Turn the **TONE** knob to select what kind of MIDI data is sent from DIG to other MIDI devices. Both LEDs will flash momentarily to indicate status.
  - **OFF: RED** (default) - No MIDI messages are sent out of DIG.
  - **THRU: BLUE** - Incoming MIDI messages are sent to the MIDI Out without any additional MIDI messages generated by DIG.
  - **SEND CC, PC, OTHER: WHITE** - MIDI CC, PC, and SysEx messages generated by DIG are all sent to the MIDI Out.
  - **SEND CC, OTHER: GREEN** - MIDI CC and SysEx messages generated by DIG are sent to the MIDI Out.
  - **SEND PC, OTHER: PURPLE** - MIDI PC and SysEx messages generated by DIG are sent to the MIDI Out.
  - **SEND OTHER: AMBER** - SysEx messages generated by DIG are sent to the MIDI Out.
- 3 Press either footswitch to store the MIDI OUT mode and exit.



## MIDI Functionality (cont.)

### Saving Presets in MIDI Mode

When in MIDI mode, the currently loaded settings can be saved to any of DIG's 300 preset locations at any time.

- 1 To enter Save mode, press and hold **BOTH** footswitches. Both LEDs will blink **GREEN** to indicate that DIG is waiting to receive a MIDI Program Change message.



- 2 To save the current state of the pedal to the currently loaded preset location, press and hold the **TAP** footswitch until the LED lights **BLUE**.



To save the current state of the pedal to any preset location, send the unit a MIDI Program Change on DIG's currently selected MIDI channel. For example:

- Send MIDI Program Change #10 to save the preset to the corresponding memory location on the pedal.
- To recall this preset, send MIDI Program Change #10 from your MIDI controller or sequencer.

**NOTE:** Press the **ON** footswitch to cancel the save operation.

## MIDI Specifications

### MIDI Program Changes

DIG contains 300 preset locations, numbered sequentially from 0-299. Because MIDI Program Change messages have a maximum number of 128 (0-127), the presets are grouped into three MIDI patch banks.

**MIDI BANK 0** = PRESETS 0-127

**MIDI BANK 1** = PRESETS 128-255

**MIDI BANK 2** = PRESETS 256-299

- 0 Favorite setting (accessible via MiniSwitch)  
See [page 23](#) for details.
- 1 MultiSwitch Plus - footswitch 1
- 2 MultiSwitch Plus - footswitch 2
- 3 MultiSwitch Plus - footswitch 3
- 127 Manual mode (“knobs”)

**NOTE:** Some MIDI applications and controllers start with MIDI Program Change 1 instead of 0. In these setups, increment the MIDI Program Change locations above by one.

DIG always powers up in MIDI Patch Bank 0, so if you plan to stay within the first 127 presets, simply send a standard MIDI Program Change message to load a preset.

If you will be using MIDI Banks 1 and/or 2, you must send a standard MIDI Bank Change message (MIDI CC# 0 with a value equal to the MIDI Bank#) before each MIDI Program Change.

Selecting bank 0, patch 127 will put DIG into Manual mode. In this mode, the pedal will be set to the current knob and switch settings. No preset data can be stored at this preset location.

## MIDI Specifications (cont.)

### MIDI CCs

DIG - MIDI CC NUMBERS			
CC#	PARAMETER	RANGE	VALUE
0	Bank Select	0-2	{0=Bank 1, 1=Bank 2, 2=Bank 3}
11	Mod	1-3	{1=off, 2=light, 3=deep}
12	Time	0-127	
13	Time 2	0-127	
14	Tone	0-127	
15	Type	1-3	{1=24/96, 2=adm, 3=12 bit}
16	Mix	0-127	
17	Mix 2	0-127	
18	Repeats	0-127	
19	Delay 1 Subdivision	0-2	{0=dotted eighth, 1=quarter, 2=half}
20	Delay 2 Repeats	0, 127	{0=delay, 1-127=track}
21	Sync/Free	0-1	{0=sync, 1=free}
22	Config	0-2	{0=series, 1=ping pong, 2=parallel}
23	Dry Level	0-127	{0-126=dry level, 127=track mix}
60	MIDI Expression Off/On	0, 127	{0=off, 1-127=on}
63	MIDI Clock Off/On	0, 127	{0=off, 1-127=on}
93	Remote Tap	Any	
97	Circular Repeats	0,127	{0=release, 1-127=hold}
100	Expression Pedal	0-127	{0=heel, 127=toe}
102	Bypass/On	0,127	{0=bypass, 1-127=on}

**NOTE:** All on/off parameters are implemented with 0=off and any other value (1-127)=on. They are documented as “0” and “127” because many MIDI controllers send out 0 and 127 for on/off switches.

**NOTE:** Some MIDI applications and controllers start their MIDI enumeration with 1 instead of 0. In these setups, increment the numbers above by one.

## Factory Reset

Performing a Factory Reset restores the pedal to its factory default Power-up modes and secondary functions, and replaces all stored pre-sets with their factory default settings.

- 1 Press and hold the **ON** footswitch while connecting power to the pedal. Once both LEDs flash, release the footswitch.



- 2 Sweep the **TIME 2** knob from 0-100% and back two times. Both LEDs will change colors at the extremes of the knob range and blink **RED** to indicate when the reset is taking place.

- TURN 1: **AMBER**
- TURN 2: **RED**
- TURN 3: **AMBER**
- TURN 4: Both LEDs flash **RED**, DIG resets and restarts.

## Factory Reset (cont.)

FACTORY DEFAULT SETTINGS	
EXP/MIDI Jack:	Assigned to Expression mode and configured to control the <b>MIX</b> knob
Input Level:	Instrument
Bypass Mode:	True Bypass
MIDI Channel:	1
MIDI Output Mode:	Off
MIDI Clock Sync:	Off
MIDI Expression:	On
Live Edit, Secondary Functions:	<p><b>DELAY 1 SUBDIVISION</b> = 12 o'clock, Quarter note</p> <p><b>DRY LEVEL</b> = 100%, Track MIX</p> <p><b>SYNC/FREE MODE</b> = 0%, Sync mode</p> <p><b>DELAY 2 REPEATS</b> = 100%, Track delay 1 REPEATS</p> <p><b>CONFIG</b> (Configuration Mode) = 0%, Series dual delay mode</p>



Default Live Edit Settings

## Features

- Two simultaneous, integrated delays, with unique digital rack delay voicings
- Each of the integrated delays provides true stereo for a total of four interactive delay lines
- Six dual delay adjustment and tone shaping knobs: Time, Time 2, Mix, Mix 2, Tone, and Repeats
- One modern and two classic digital delay voicings: 24/96, adm, and 12 bit
- Five rhythmic subdivisions: Triplet, Eighth, Golden Ratio, Dotted Eighth, and Dotted Quarter
- Three choices for delay line modulation: off, light, and deep
- Five Live Edit, secondary functions for deep control: Dry Level, Configuration Mode, Sync/Free Mode, Delay 1 Subdivision, and Delay 2 Repeats
- Selectable Free Mode disables subdivisions and synchronization
- Press and hold Circular Repeats effect
- Remote switching of TAP Tempo with a Strymon MiniSwitch
- 20ms - 1.6s delay range (40ms - 3.2s with Half Note Delay 1 Subdivision)
- Ultra low noise, high performance A/D and D/A converters
- True bypass (electromechanical relay switching)
- +10dBu maximum input level easily handles instrument and line signals
- Expression pedal input allows the connection of a TRS expression pedal, Strymon MiniSwitch, MultiSwitch Plus, or TRS MIDI connection
- Full featured MIDI accessible via TRS supporting MIDI CCs, MIDI Clock sync, and access to 300 preset locations (requires Strymon MIDI EXP cable or MIDI > TRS interface such as Strymon Conduit)
- USB-C jack for controlling via MIDI from a computer or for performing potential future firmware updates
- High performance 520MHz ARM Superscalar processor
- 32-bit floating point processing
- Stereo input (requires TRS adapter cable) and stereo output
- High impedance ultra-low noise discrete Class A JFET preamp inputs
- Low impedance stereo outputs
- Strong and lightweight anodized aluminum chassis

- Designed and built in the USA

## **Specifications**

<b>Input Impedance:</b>	1 Meg Ohm
<b>Output Impedance:</b>	100 Ohm
<b>A/D &amp; D/A:</b>	24-bit, 96kHz
<b>Max Input Level</b>	+10 dBu
<b>Signal/Noise</b>	115 dB typical
<b>Bypass Switching</b>	True Bypass (electromechanical relay switching)
<b>Dimensions</b>	4.5" deep x 4" wide x 1.75" tall

## **Power Adapter Requirements**

Use an adapter with the following rating: 9VDC, center negative, 300mA minimum.

# Appendix 1: Sample Settings



# Sample Settings

## CASCADING ECHOES



MIDI Program Change 0  
MiniSwitch Favorite

## DOWN FROM THE HILLS



MIDI Program Change 1  
MultiSwitch Plus A

## SUBTLE REPEATS



MIDI Program Change 2  
MultiSwitch Plus B

## DISTINCT BOUNCES



MIDI Program Change 3  
MultiSwitch Plus C

## SHORT ROOM



MIDI Program Change 4

## LIVE EDIT FUNCTIONS

DIG provides a way to adjust several parameters that do not have a dedicated knob or switch. These are called **LIVE EDIT** functions and each are described in detail starting on [page 7](#). The sample settings on this page use the factory default values for these functions.

# Appendix 2: Power Up Modes Quick Reference

## Power Up Modes Quick Reference

Global parameters and functions can be accessed via a power up procedure. All power up functions persist through power cycles.

### General Options

- 1 Press and hold the **ON** footswitch while powering up DIG. Once both LEDs flash, release the footswitch.
- 2 Adjust the desired functions with the knobs and buttons noted below.
- 3 Press either footswitch to store your changes and exit power up mode.

---

#### INPUT LEVEL

See [page 17](#) for an illustrated description.

Turn **TIME** knob - status shown on both LEDs:

- Instrument: **GREEN** (default)
- Line: **RED**

---

#### BYPASS MODE

See [page 18](#) for an illustrated description.

Turn **MIX** knob - status shown with **ON** LED:

- True Bypass: **GREEN** (default)
- Buffered Bypass: **RED**

---

#### SPILLOVER MODE

See [page 19](#) for an illustrated description.

Turn **TONE** knob - status shown on both LEDs:

- Spillover Off: **AMBER** (default)
- Spillover On: **PURPLE**

---

#### FACTORY RESET

See [page 36](#) for an illustrated description.

Turn **TIME 2** knob from 0% to 100% and back two times - status shown on both LEDs

---

## Power Up Modes Quick Reference (cont.)

Global parameters and functions can be accessed via a power up procedure. All power up functions persist through power cycles.

### MIDI & Jack Options

- 1 Press and hold the **TAP** footswitch while powering up DIG. Once both LEDs flash, release the footswitch.
- 2 Adjust the desired functions with the knobs and buttons noted below.
- 3 Press either footswitch to store your changes and exit power up mode.

---

**EXP/MIDI JACK** Turn **MIX** knob - status shown with **ON** LED

#### MODE

See [page 20](#) for an illustrated description.

- Expression: **GREEN** (default)
- Favorite: **AMBER**
- Tap: **RED**
- MIDI: **BLUE**

---

**MIDI CHANNEL** Turn **TIME** knob - status shown on **TAP** LED

See [page 30](#) for an illustrated description.

- 1: **GREEN** (default)
- 2: **AMBER**
- 3: **RED**
- 4-16: **BLUE** (channel set by next MIDI Program message)

---

**MIDI OUT MODE** Turn **TONE** knob - status shown momentarily on **both** LEDs

See [page 32](#) for an illustrated description.

- OFF: **RED** (default)
  - THRU: **BLUE**
  - ON CC PC OTHER: **WHITE**
  - ON CC OTHER: **GREEN**
  - ON PC OTHER: **PURPLE**
  - ON OTHER: **AMBER**
-

# Appendix 3: Live Edit Controls Quick Reference

## Live Edit Controls Quick Reference

DIG provides a way to adjust several secondary functions that are available on several knobs (see [“Live Edit Functions” on page 7](#)). Live Edit functions are saved per preset.

- 1 Press and hold the **ON** footswitch until both LEDs blink to enter Live Edit mode.
- 2 Release the footswitch and use the knobs as described below.
- 3 Press **ON** footswitch to store your setting and exit Live Edit mode.

### DRY LEVEL

See [page 7](#) for an illustrated description.

Turn the **MIX** knob—both LEDs change color from **GREEN** (no dry signal) to **AMBER** (unity gain with input). Turn to maximum knob position to **BLUE** (Track Mix, the default, where wet/dry balance is adjusted via **MIX** and **MIX 2** knobs)

### CONFIG (dual delay mode)

See [page 9](#) for an illustrated description.

Turn the **MIX 2** knob—the **ON** LED changes color from **GREEN** (left - Series, the default), to **AMBER** (center - Ping Pong), to **RED** (right -Parallel)

### SYNC/FREE MODE

See [page 12](#) for an illustrated description.

Turn the **TIME 2** knob—both LEDs change color from **GREEN** (Sync, the default) to **RED** (Free)

### DELAY 1 SUBDIVISION

See [page 13](#) for an illustrated description.

Turn the **TIME** knob—the **TAP** LED changes color from **GREEN** (left - Dotted Eighth note), to **AMBER** (center - Quarter note, default), to **RED** (right - Half note)

### DELAY 2 REPEATS

See [page 14](#) for an illustrated description.

Turn the **REPEATS** knob clockwise from left—both LEDs change smoothly from **GREEN** (single repeat) to **AMBER** (maximum feedback). Turn to maximum knob position to **RED** (Track Repeats, the default, where Delay 2 follows Delay 1 repeats)

### MIDI CLOCK SYNC

See [page 15](#) for an illustrated description.

Set the **TYPE** switch to the **12 bit** (down) or **24/96** (up) position—status is momentarily shown on both LEDs:

- **12 bit position:** OFF, **RED** (default)
- **24/96 position:** ON, **BLUE**

### MIDI EXPRESSION

See [page 16](#) for an illustrated description.

Set the **MOD** switch to the **deep** (down) or **off** (up) position—status is momentarily shown on both LEDs:

- **deep position:** OFF, **RED**
- **off position:** ON, **BLUE** (default)

## **Strymon Non-Transferable Limited Warranty**

### **Warranty**

Strymon warrants the product to be free from defects in material and workmanship for a period of two (2) years from the original date of purchase when bought new from an authorized dealer in the United States of America or Canada. If the product fails within the warranty period, Strymon will repair or, at our discretion, replace the product at no cost to the original purchaser. Please contact your dealer for information on warranty and service outside of the USA and Canada.

### **Exclusions**

This warranty covers defects in manufacturing discovered while using this product as recommended by Strymon. This warranty does not cover loss or theft, nor does the coverage extend to damage caused by misuse, abuse, unauthorized modification, improper storage, lightning, or natural disasters.

### **Limits of Liability**

In the case of malfunction, the purchaser's sole recourse shall be repair or replacement, as described in the preceding paragraphs. Strymon will not be held liable to any party for damages that result from the failure of this product. Damages excluded include, but are not limited to, the following: lost profits, lost savings, damage to other equipment, and incidental or consequential damages arising from the use, or inability to use this product. In no event will Strymon be liable for more than the amount of the purchase price, not to exceed the current retail price of the product. Strymon disclaims any other warranties, expressed or implied. By using the product, the user accepts all terms herein.

### **How to Obtain Service Under this Warranty**

For North American customers: Contact Strymon through our website at [strymon.net/support](https://strymon.net/support) for Return Authorization and information. Proof of original ownership may be required in the form of a purchase receipt.

For International Customers: Contact the Strymon dealer from which the product was purchased from in order to arrange warranty repair service.

Strymon® is a division of Damage Control Engineering®, LLC.